



Technical Specification



1200X Series Granulators

Tel (262) 641-8600 • Fax (262) 641-8653 • www.cumberland-plastics.com • Bulletin: CG2-521.2 • Effective: June 14, 2010 • Supersedes: CG2-521.1

1200X Series Granulators

Application:

The 1200X Series granulators offer a wide range of capabilities to handle the most demanding injection molding, blow molding, and extrusion requirements. With a horsepower range from 7 ½ to 25 HP (5.5 kW to 18.6 kW), throughput capacities from 500 to 800 lbs/hr, and a wide range of sizes, there is a Cumberland granulator ideal for your specific needs. The 3-knife open slant-cut rotor with scooped wings provides for both positive feeding of bulky parts and improved airflow for cooler operation. Rotating end discs reduce heat and abrasion.

Benefits:

- TEFC motor and solid flywheel drive
- Metal bin discharge
- Hopper
 - Hand, robot, or conveyer operation
 - Sound attenuated
 - Multi-feed
- Cutting Chamber
 - Offset design; 2 bed knives
 - Sound attenuated
 - Multi-feed
- 3-knife rotor
 - Open slant-cut with scooped wings
 - Rotating end discs
- Quick release hand knob access
- Rotor and bed knives
 - D2 OEM manufactured
 - Proprietary process
- Removable pivoting drop-down screen and screen cradle
 - 5/16" standard
- 3/16", 1/4", 3/8" and other sizes available Controls
 - NEMA type 12 with 120v P/B 230/460V

Specifications

Selector Guide												
Features	In-feed	Rotor	Base		Discharge				Motor/ Controls	Drive Parts	Throughput	Weight
	Tray feed Removable flap top assembly Double-walled SP	3-knife open slant cut	Portable caster mount	Stationary vibration pad	Metal bin	Pneumatic 4" (101mm) 5" (172mm) 6" (152mm)	Vacuum or Gaylord	Evacuation System	TEFC 230/460V Start/Stop P/B Controls	Solid High-Inertia Flywheel V-belt Drive	Lbs/hr (kgs/hr) 5/16" Screen 3-knife Rotor (approx.)	Lbs. (kgs)
1212X	Tray & Sheet	STD	STD	Opt.	STD	Opt.	Opt.	Opt.	7½ - 25 HP (5.5 - 18.6 kW)	STD	500 (227)	1750 (794)
1218X	Tray & Pipe								7½ - 25 HP (5.5 - 18.6 kW)		750 (318)	2300 (1043)
1224X	Tray & Feed Rolls								10 - 25 HP (7 - 18.6 kW)		900 (408)	2850 (1292)



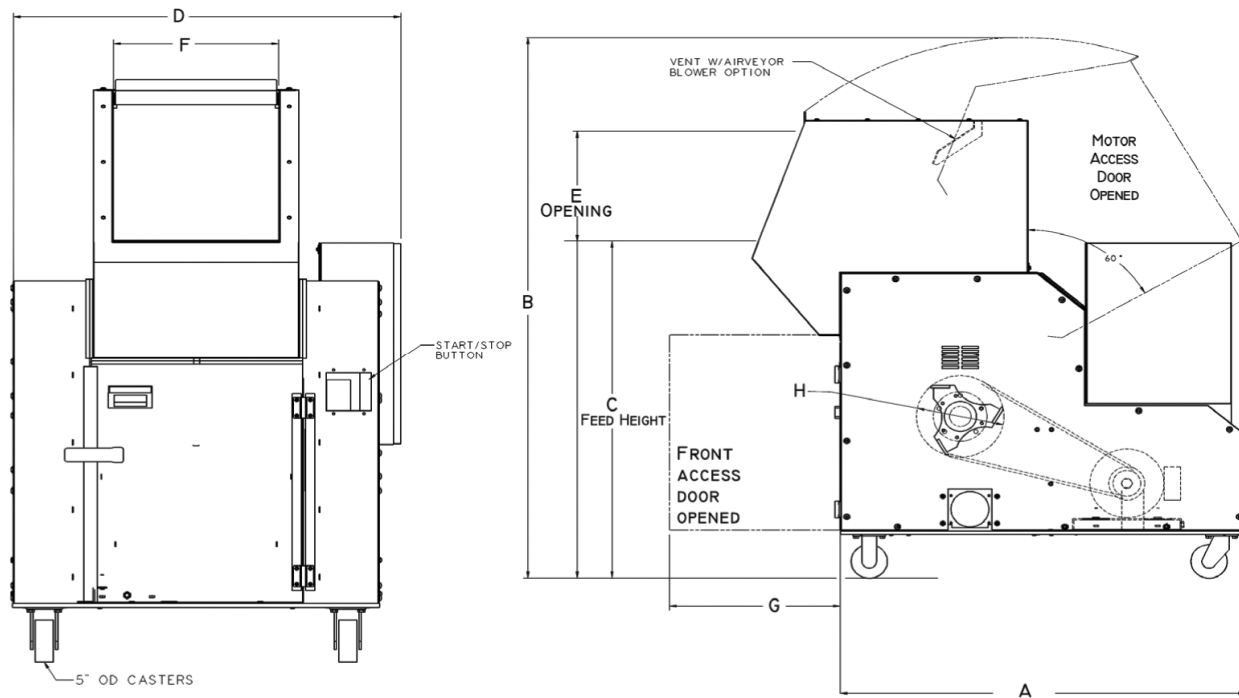

Dimensions								
Model	A	B	C	D	E	F	G	H
GP1212				36 3/4" (933 mm)	17" (1700 mm)	12 1/4" (431 mm)	17 5/8" (448 mm)	12" (305 mm)
GP1218	56" (1422 mm)	80 1/4" (2038 mm)	50 1/4" (1276 mm)	42 3/4" (1085 mm)		18 1/2" (470 mm)	23 1/2" (597 mm)	
GP1224				48 3/4" (1238 mm)		24 1/4" (616 mm)	15" (381 mm) (2 doors)	