



Technical Specification



Auger-Fed Granulators

Tel (262) 641-8600 • Fax (262) 641-8653 • www.cumberland-plastics.com • Bulletin: CG1-510.1 • Effective: June 14, 2010 • Supersedes: CG1-510.1

Auger-Fed Granulators

Application:

Cumberland's Auger-Fed Granulators are fully portable and automatic, with a small footprint. They are designed for continuous, heavy-duty applications, such as runners, sprues, blow-molded scrap, small thin wall parts, and pre-cut thermoformed web.

Features:

Model	Throat Size	Cutting Circle Diameter	Throughput	Approximate Weight
6 x 8	6" x 8" (15 x 20 cm)	6" (152 mm)	175 lbs./hr. (79 kg.)	650 lbs. (296 kg.)
8 x 12	8" x 12" (20 x 30 cm)	8" (203 mm)	250 lbs./hr. (113 kg.)	1300 lbs. (591 kg.)
12 x 16	12" x 16" (30 x 40 cm)	12" (305 mm)	450 lbs./hr. (204 kg.)	2400 lbs. (1090 kg.)

Benefits:

- 3 slanted rotor knives and 2 counter-slanted bed knives create a unique shearing action that eliminates jamming in the chamber while producing cleaner, more uniform granulate.
- Reversing flight of the continuous welded auger screw prevents annoying wrap around of the runners before entering the cutting chamber.
- Oversized auger and infeed openings can be customized to suit your application.
- Lockout chain and emergency stop push button mounted at end of auger trough for added safety.

Specifications:

	Standard	Standard Options
Infeed	Hopper, one-piece reversed flight auger	Increased or decreased auger length, adjustable fifth wheel at auger end
Cutting Chamber	Slant cut shearing design with screen drawer and hinged lid	Hardface welding (8 x 12 and 12 x 16 models only)
Rotor	D2	Carbide coating, Hardface welding (6 x 8 and 8 x 12 models only)
Rotor Knives	3	
Bed Knives	2	
Screen	Corten reversible screen, 5/16"	Carbide coating, 1/8", 3/16", 1/4"
Base	Two swivel casters, two fixed casters	3" (76.2mm), 4" (101.6mm), and 6" (152.4) base leg extensions
Discharge	Bin	Oversized collection bin, Pneumatic evacuation system
Motor	6 x 8: 3HP (2.2kW), 5HP (3.7kW) 8 x 12: 5HP (3.7kW), 7.5 HP (5.5kW) 12 x 16: 10 HP (7.5kW), 15HP (11kW)	
Drive Parts	Heavy-duty auger chain drive	
Electrical Components	Fused disconnect, NEMA 12 magnetic across-the-line starter control	
Controls	208, 230, 460 or 575 V	
Labels	English	
Accessories		

— See Page 2 For Auger Fed Granulator Drawing —



Cumberland Auger-Fed Granulators

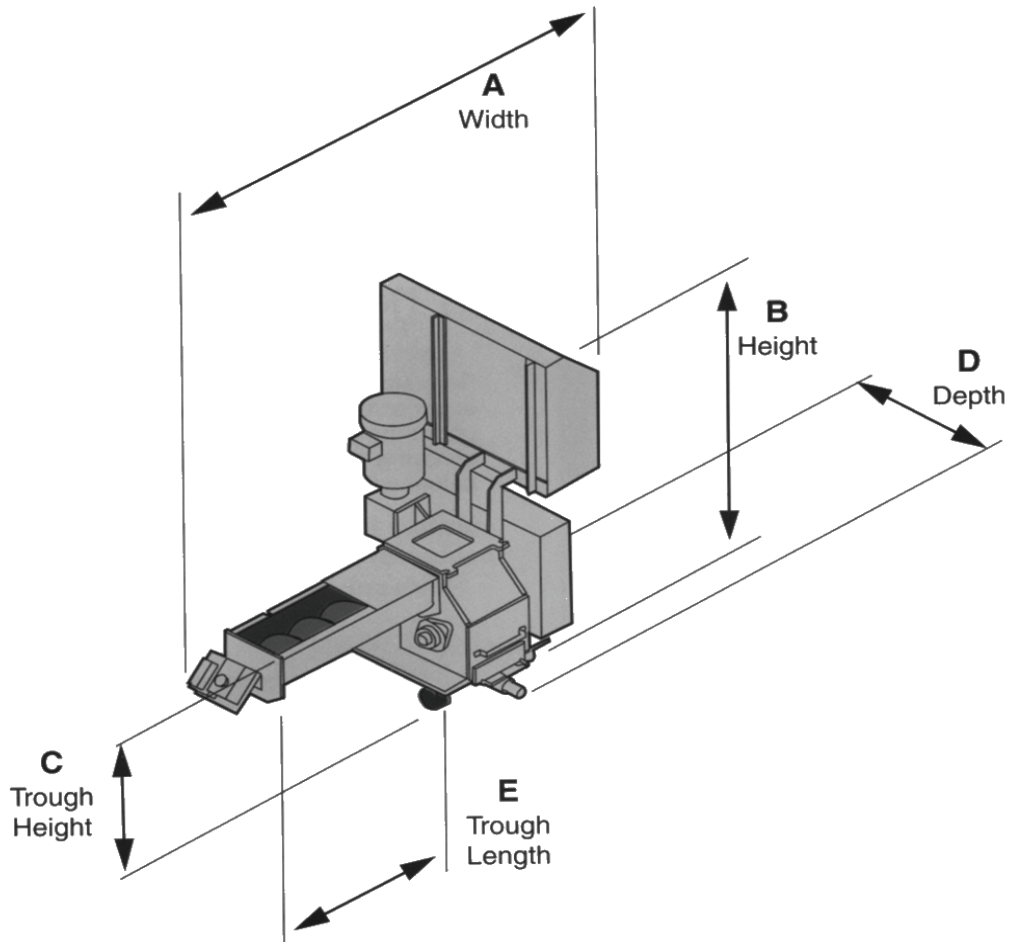

Dimensions

Model	A	B	C	D	E
6x8	55" (1397mm)	49.25" (1250mm)	18" (457mm)	28" (711mm)	20.75" (527mm)
8x12	81.5" (2070mm)	57" (1447mm)	25.25" (641mm)	34.5" (876mm)	43.5" (1104mm)
12x16	87.5" (2222mm)	68.5" (1739mm)	32.25" (819mm)	48" (1219mm)	44" (1117mm)