

## B Series Central Granulators

Open wing rotor with large diameter shaft provides extra strength while allowing maximum airflow and reduced noise

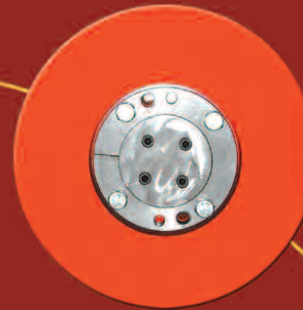

Solid flywheel adds additional inertia to the cutting operation



Heavy-duty double roller bearings provide years of trouble free operation



Various application specific feed hoppers are available including tray, conveyor feed, pipe feed, sheet feed, and feed rolls



### B Series Granulators Offer High-Capacity Reclamation

Cumberland B Series heavy duty granulators are designed for high capacity central reclamation. They can granulate a wide range of plastic scrap, from low density fiber to thick, high molecular weight purgings and can be integrated with a variety of handling equipment.

The B Series comes in 37" and 50" widths with throughputs from 2500–4000 lbs/hr. Designed for many years of rugged use, the B Series combines bolted and dowelled heavy steel construction with Cumberland's "Chevron" rotor style provide years of worry free production.

# B Series Central Granulators

## Standard Features

- High shear rotor
- Internal surfaces machined for ease of clean out and material flow
- Heavy duty double roller bearings mounted outboard to avoid contamination
- Designed for high capacity central reclamation

Specifications						
Model	24B	28B	37B	50B	62B	72B
Throat Size, in.	15x24	18x28	18x37	20x50	20x62	20x72
Cutting Circle, in.	14	16	16	18	18	18
Throughput (3/8" screen)	1000	1800	2500	3500	4500	5000
Infeed	Conveyor					
Cutting Chamber	(2) Bed					
Rotor	Open 3-Blade					
Rotor Knives	(3) HCHC					
Bed Knives	(2) HCHC					
Screen Diameter	3/8"					
Base	Step Type					
Discharge	Airveyor					
Motor (tefc)	75 hp	100 hp	100 hp	150 hp	200 hp	200 hp
Drive	V-Belt					
Electrical Components	Safety switches wired to common junction box					
Controls	To suit voltage, 110V at operator station					
Accessories	Available upon request					
Feed Height, in.	90	104	104	112	112	112
Length, in. (mm)	53 (1346)	46 (1168)	46 (1168)	46 (1168)	46 (1168)	46 (1168)
Width, in. (mm)	73 (1854)	117 (2972)	135 (3429)	140 (3556)	145 (3683)	171 (4343)
Height, in. (mm)	107 (2718)	135 (3429)	127 (3226)	164 (4166)	164 (4166)	164 (4166)
Weight (lbs)	6000	7000	11,000	15,000	22,000	26,000

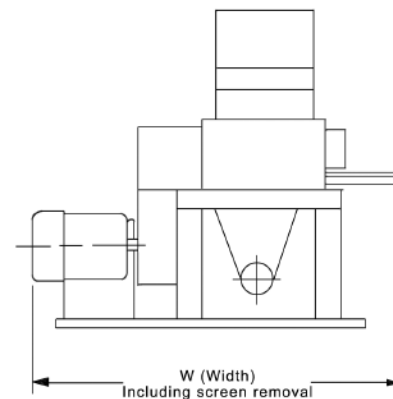
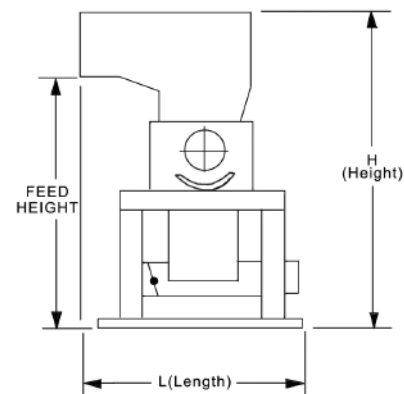

### CORPORATE HEADQUARTERS

2900 S. 160th Street  
 New Berlin, WI 53151  
 TEL: (262) 641-8600  
 FAX: (262) 641-8650  
[www.cumberland-plastics.com](http://www.cumberland-plastics.com)

### REGIONAL SERVICE CENTERS (800) 229-2919

ACS Tech Center  
 4100 Market Place  
 Flint, MI 48507  
 TEL: (810) 720-7300  
 FAX: (810) 720-2598

ALL DATA SUBJECT TO CHANGE WITHOUT NOTICE

©2010 Cumberland Engineering

Bulletin CG6-130.2