

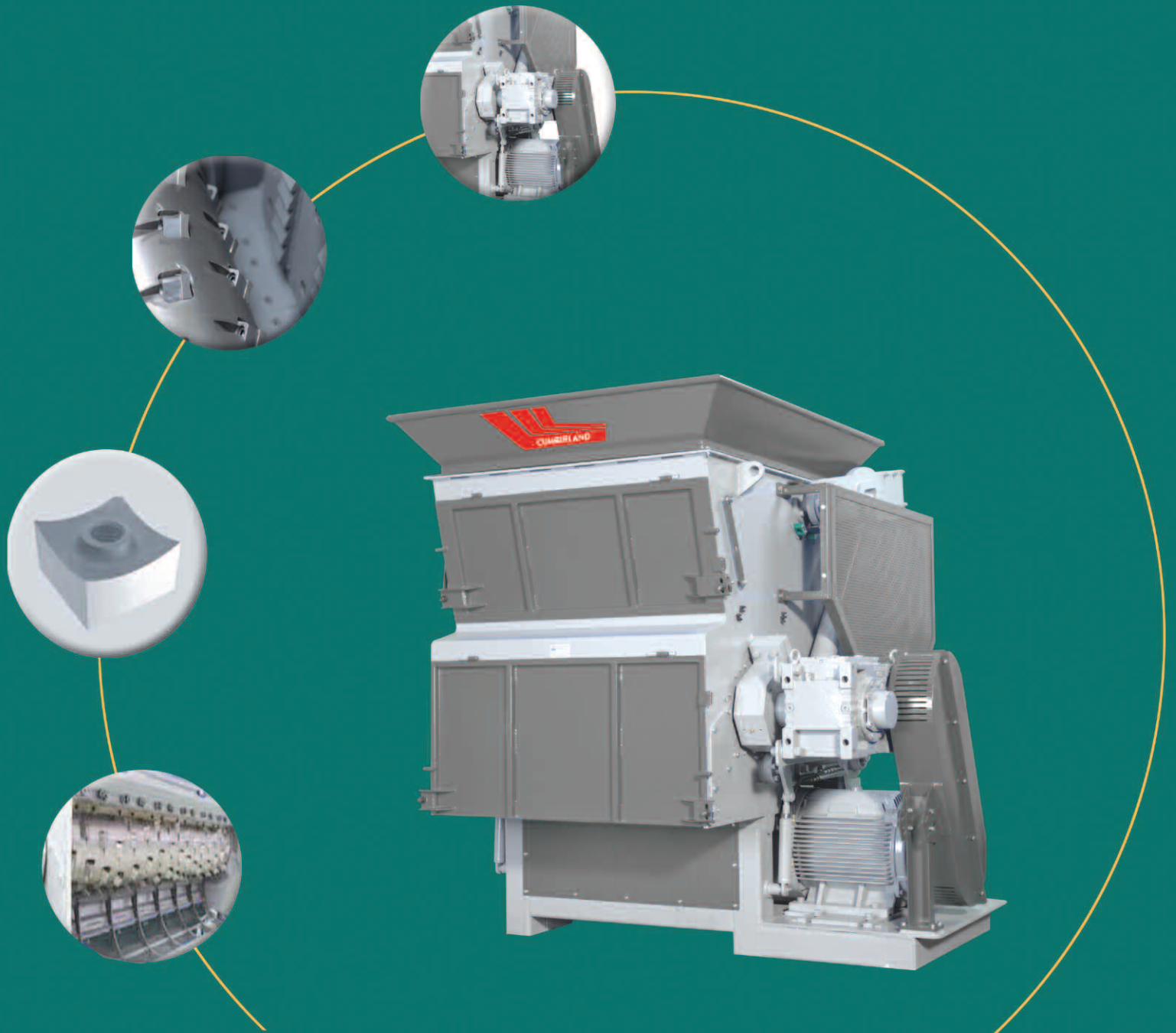

CMS Series Medium Duty Single Shaft Shredder



Rugged Construction For Demanding Applications

The CMS Series is designed for processing scrap from wood industries—miscellaneous trim and panel scraps, furniture, injection and extrusion mold startup purge, heavy wall parts, paper and cardboard, film (baled and loose). It reduces material to approximately 1" to 4" based on screen sizes when combined

with a Cumberland granulator (stacked 2 stage or in-line with conveyors) output material sizes can range from 1/8" to 1/2" and the granulator can average 150% of its stated throughputs without heavy power consumption loads typically seen when using a granulator alone.

CMS Series Medium Duty Single Shaft Shredder

Features and Benefits

- 18" diameter (15" on the CMS 850 model) drum style rotor provides efficient cutting of various process scrap
- Low speed rotor (102 rpm) transmits high cutting torque for tough applications
- The low speed cutting action reduces noise levels
- Standard rotor is fabricated using abrasion resistant steel for long life in high wear applications
- 4 edge 1.3" (34mm) reversible cutters with bolt in replaceable knife seat for easy maintenance
- "Swing style" hydraulic ram along with the tangential cutting chamber design allows material to maintain contact with the rotor on both cycles of the ram
- "Swing style" ram enables reduced footprint
- Two speed 7.5hp (5hp on the 850) ram hydraulic system maximizes pressure while shredding that changes to high speed while not contacting material
- Heavy duty self aligning outboard mounted bearings that reduce the possibility of material contamination
- Multiple doors for easy access during cleaning and maintenance

Specifications				
Model	850	1200	1500	2000
Hopper Feed Opening, in. (mm)	33.1 x 52.8 (840 x 1340)	44.1 x 61.8 (1120 x 1570)	55.1 x 61.8 (1400 x 1570)	77.2 x 61.8 (1960 x 1570)
Usable Area of Cutting Chamber, in. (mm)	27.6 x 28.7 (700 x 730)	31.5 x 39.8 (800 x 1010)	31.5 x 50.8 (800 x 1290)	31.5 x 72.8 (800 x 1850)
Rotor Dia., in. (mm)	15.2 (387)	18 (457)	18 (457)	18 (457)
Rotor Speed (rpm at 60Hz)	102			
No. of D2 Rotor Cutters (34mm x 34mm)	60	81	102	144
No. of D2 Bed Knives (4-edge)	6	8	10	14
Standard Motor, hp (KW)	50 (37)	75 (55)	100 (75)	2 x 75 (2 x 55)
Motor of Hydraulic Device, hp (kW)	5 (3.7)	7.5 (5.6)	7.5 (5.6)	7.5 (5.6)
Machine Weight, lbs (kg)	10,584 (4800)	14,333 (6500)	17,640 (8000)	20,948 (9500)

Dimensions, mm (in.)				
	CMS 850	CMS 1200	CMS 1500	CMS 2000
A	2070 (81)	2280 (90)	2280 (90)	2280 (90)
B	1445 (57)	1650 (65)	1650 (65)	1650 (65)
C	485 (19)	540 (21)	540 (21)	540 (21)
D	560 (22)	660 (26)	660 (26)	660 (26)
E	2100 (83)	2250 (89)	2250 (89)	2250 (89)
F	260 (10)	260 (10)	260 (10)	260 (10)
G	1830 (72)	2190 (86)	2700 (106)	3560 (140)
H	1550 (61)	1960 (77)	2340 (92)	3050 (120)
I	840 (33)	1120 (44)	1400 (55)	1960 (77)
J	860 (34)	1140 (45)	1420 (56)	1980 (78)
K	1360 (54)	1570 (62)	1570 (62)	1570 (62)

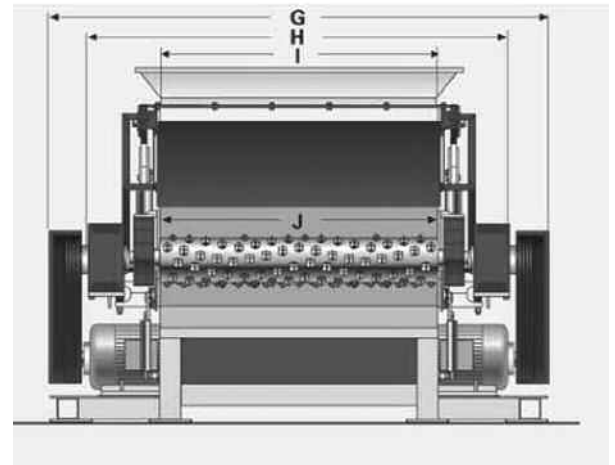
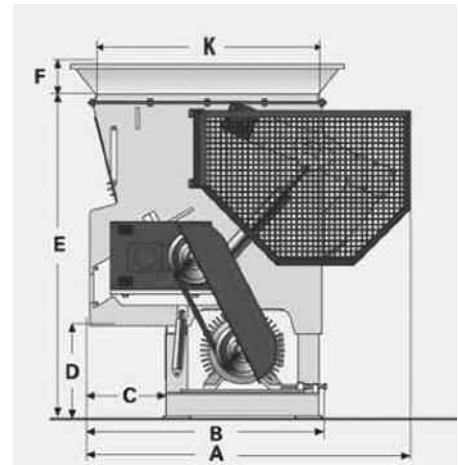

CORPORATE HEADQUARTERS

2900 S. 160th Street
 New Berlin, WI 53151
 TEL: (262) 641-8600
 FAX: (262) 641-8653
www.cumberland-plastics.com

REGIONAL SERVICE CENTERS (800) 229-2919

ACS Tech Center
 4100 Market Place
 Flint, MI 48507
 TEL: (810) 720-7300
 FAX: (810) 720-2598

ALL DATA SUBJECT TO CHANGE WITHOUT NOTICE

©2010 Cumberland Engineering

Bulletin CG6-195.1