



Technical Specification



CXS Series Single Shaft Shredder

Tel (262) 641-8600 • Fax (262) 641-8653 • www.cumberland-plastics.com • Bulletin: CG7-540.1 • Effective: June 14, 2010 • Supersedes: CG7-540

CXS Series Single Shaft Shredder

Application:

The CXS Series shredder is designed for processing plastic waste for reclamation and recycling large extruder purgings, reject parts, trim scraps, baled or loose film, synthetic fiber, wood processing scrap, medical waste, cardboard, paper, and carpet.

Features

Model	Hopper Feed Opening, in (mm)	Cutting Chamber, in (mm)	Motor, hp (kW)
CXS 1500	100 x 63 (2540 x 1600)	59 x 58 (1499 x 1473)	2 x 100 (2 x 74.5)
CXS 2000	100 x 79 (2540 x 2007)	59 x 75 (1499 x 1905)	2 x 100 (2 x 74.5)
CXS 3000	100 x 111 (2540 x 2819)	59 x 106 (1499 x 2692)	2 x 150 (2 x 111.8)

Benefits:

- Sturdy ram construction that incorporates heavy-duty guide bearings and universal couplings for reliable operation.
- Serrated ram plates for easy processing of large awkward pieces.
- Heavy-duty outboard bearings minimize risk of contamination.
- Rotors equipped with square cutter blocks for efficient cutting of material while reducing heat build-up and degradation.
- Large 29.5" diameter rotor for positive ingestion.
- Abrasion-resistant rotor standard for long life.
- Bolted-in cutter seat for easy removal and maintenance.
- Easy knife and screen access.
- Specialized rotors with hardened alloys for demanding applications.
- Standard feed hopper design allows feeding via tipping skip as well as manual feeding of large bulky parts.
- Two-speed ram hydraulics.

Optional Features:

- Hydraulic screen cradle
- Rotor cooling
- PLC with display
- Chamber-wear protection
- Infeed and discharge conveyors
- Easily configured with 2nd stage granulation

CXS Series Specifications:

Model	Number of Rotor Knives	Number of Bed Knives	Rotor Diameter, in (mm)	Rotor Speed, RPM	Motor of Hydraulic Device, HP (kW)	Screen Sizes, in (mm)
CXS 1500	76	4	29.5 (750)	54	15 (11.1)	1-4 (25.4-101.6)
CXS 2000	96	5				
CXS 3000	136	7				

Model	Mounted Knife holders	Hopper for Manual/ Conveyor Feed	Hydraulic Feeding ram	Two Speed Turbo-Hydraulic	Ram Comb. Plate	Control Panel SPS	Ampere-Meter in Control Cabinet
CXS 1500	Included	Included	Included	Included	Included	Included	Included
CXS 2000							
CXS 3000							

— See Page 2 For CXS Series Drawings —



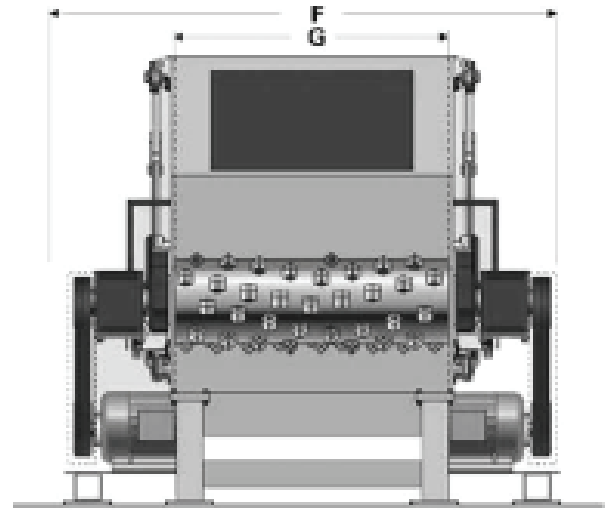
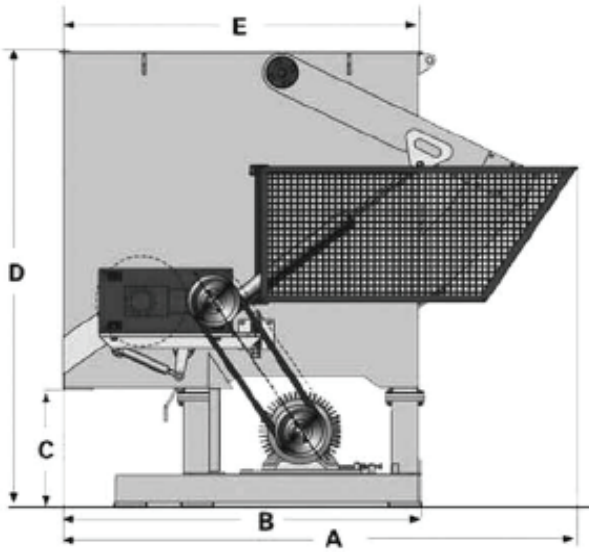

Dimensions, in. (mm)	CXS-1500	CXS-2000	CXS-3000
A	142 (3607)		
B	102 (2591)		
C	34 (864)		
D	132 (3353)		
E	100 (2540)		
F	126 (3200)	155 (3937)	193 (4902)
G	64 (1625)	80 (2032)	111 (2819)