

T Series Thermoform Granulator

Hydraulic assisted hopper hinge provides quick access and knife adjustments



6-inch airveyor discharge with optional blower simplifies removal of granulated material



Internal surfaces of the solid steel cutting chamber are machined to an exceptionally smooth finish

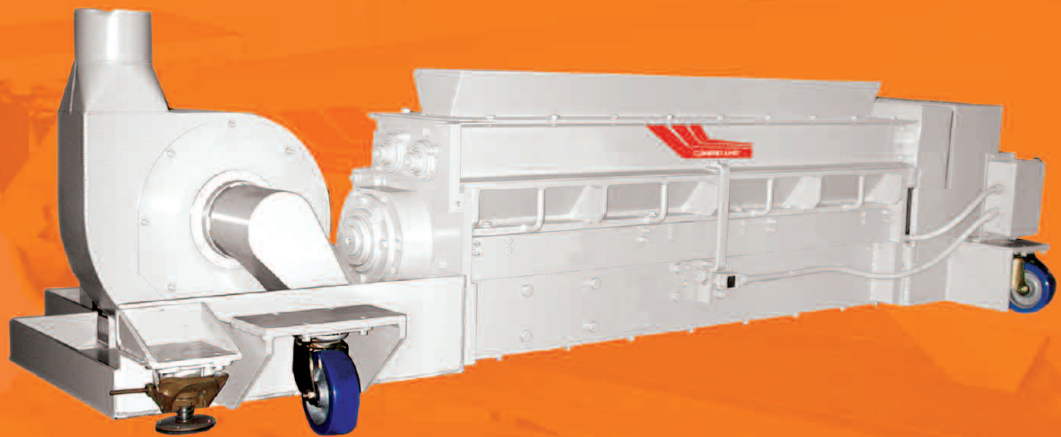

Caster-mounted base allows for easy re-positioning



Compact Granulators for Inline Processing of Thermoformed Scrap

The Cumberland T Series granulators are designed for continuous reclamation of skeletal web directly from the thermoform trim process. The low profile T Series can be positioned directly beneath the trim press for on-line operation with continuous airveyor removal. Throughput matches thermoformer output, up to 1500 lbs./hr.

For low-power, low-RPM operation, six knives are mounted in an offset pattern on the alloy steel rotor in conjunction with two adjustable, stationary knives with double cutting edges. This means more lineal inches of cut, more capacity, and less likelihood of plugging. A front access door lifts off to fully expose both screens.

T Series Thermoform Granulator

Standard Features

- Double-sealed outboard rotor bearings preclude contamination. All other bearings in the machine are double-sealed for long life reliability
- Split rotor knives are offset for optimum cutting efficiency and power consumption
- Screens, mounted in swing-down cradles, are easily removed from the front of the machine
- Adjustable bed knives have two cutting edges, and are reversible for extended life

Available Options

- Paddle rolls or horizontal infeed hopper
- 1/4", 3/8", and larger screens
- 10 HP, 15 HP, 20 HP motors
- 1 HP, D.C. feed roll motor
- Machine-mounted blower
- Blower sound-enclosure

Specifications	
Infeed	Spring loaded driven feed roll-poly smooth
Cutting Chamber	Solid steel sections up to 4" thick, internally ground to a high finish; 2 reversible bed knives, HCHC, opposing high chrome, high carbon steel, adjustable; 7.9" Diameter Cutting Circle
Rotor	Full body, high alloy steel, 3 knife slant cut; 6 high chrome, high carbon steel knives; steep angle, keen edge, in offset pattern
Motor	7.5 HP, 1800 RPM
Screen	5/16", reversible, 36T 1 piece, 56T 2 Piece

Model	A	B
36T	36"	39.75"
56T	56"	59.75"

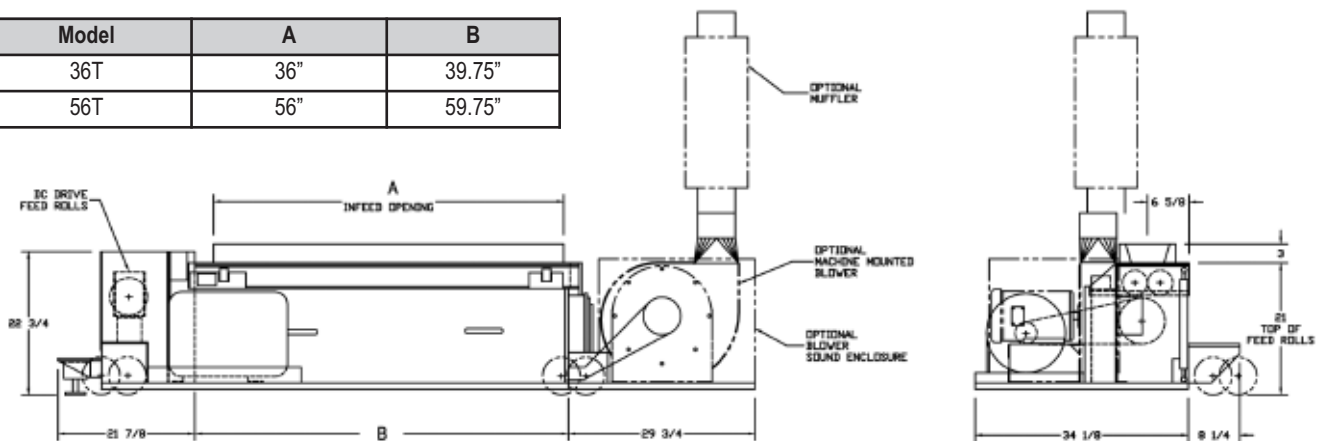

CORPORATE HEADQUARTERS

2900 S. 160th Street
New Berlin, WI 53151
TEL: (262) 641-8600
FAX: (262) 641-8653

www.cumberland-plastics.com

REGIONAL SERVICE CENTERS (800) 229-2919

ACS Tech Center
4100 Market Place
Flint, MI 48507
TEL: (810) 720-7300
FAX: (810) 720-2598

ALL DATA SUBJECT TO CHANGE WITHOUT NOTICE

©2010 Cumberland Engineering

Bulletin CG5-105.2