



U Series Granulators

Application:

The U Series Thermoforming granulators offer a wide range of capabilities and are ideal for under-the-press or in-front-of-the press applications. Three models provide various throat sizes—12x44, 12x56, and 12x74. Models feature powers from 20 to 50 HP (14.9 to 37.2kW) and throughput capacities of 1800 to 3000 lbs/hr (816 to 1360 kgs/hr). Reversible screens are available in various sizes, and the complete regrind evacuation is achieved with an 8 in. (203mm) blower system. The castered base is portable and low profile, which allows for under-the-press positioning.

Benefits:

- The two pivoting doors offer complete access into the bottom of the cutting chamber (screen cradle and screen). The larger 12" (305mm) cutting circle and open screen area allow maximum throughput.
- Two swing open doors allow easy access to the screen cradles and screen.
- The 3-blade open rotor with Twinshear cutting geometry offers quieter, cooler operation and is ideal for polypropylene.
- Pneumatic upper hopper opening allows for easy access. Rotor and bed knives are easily accessed by tilting open the upper chamber.

Specifications (Consult Factory for Special Options):

Model	44U	56U	74U
Throat size, in. (mm)	12x44 (305x1118)	12x56 (305x1422)	12x74 (305x1880)
Cutting circle diameter, in. (mm)	12 (305)		
Feed height, in.(mm)	30 (762)		
Throughput, lbs/hr (kgs/hr)	1800 (816)	2200 (998)	3000 (1361)
Working Envelope, LxW, in.(mm)	91x73 (2311x1854)	103x73 (2616x1854)	121x73 (3073x1854)
Weight, lbs. (kgs)	4000 (1814)	5300 (2404)	8000 (3629)
Motor (rotor drive), hp (kW)	20 – 50 (14.9 – 37.2)		
Motor (feedrole drive), hp (kW)	5 (3.7) AC		
Controls	230/460v: 115V P/B (standard); 208/575V: 115V P/B (optional)		
Rotor	3-knife open Twinshear (standard); 5-knife open Twinshear (optional)		

Standard Features:

- 3-knife "open" Twinshear rotor; optional 5-blade open rotors available.
- Bolted and doweled construction.
- Pivoting screen cradle.
- 2 bed knives—reversible D2
- Rotor knives hi-angle
- Feed roll motor (3 hp (2.2kW) AC)
- Oversized 7" (1779 mm) diameter Steel Knurled Feed Rolls; optional paddle rolls are available.
- 12" (305mm) cutting circle
- Low profile caster base
- 8" pneumatic discharge
- NEMA 12 controls
- 1 year warranty on parts and labor

— See Page 2 For C Series Drawings —



Cumberland U Series Granulators

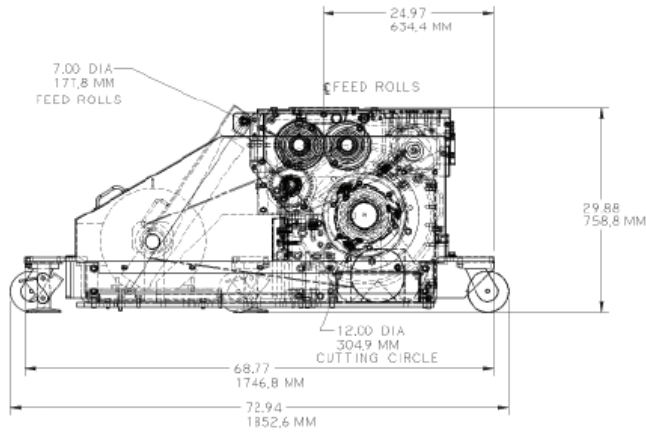
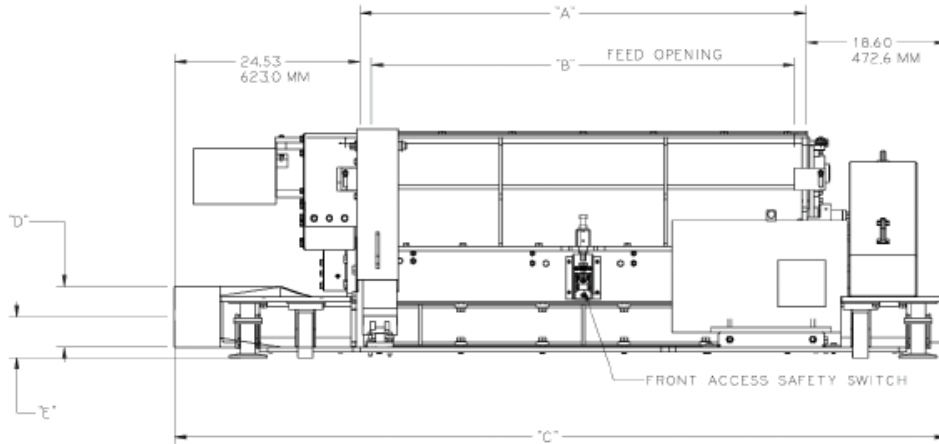

Dimensions

Model	A, in. (mm)	B, in. (mm)	C, in. (mm)	D, in. (mm)	E, in. (mm)
44U	47 (1194)	44 (1118)	91 (2311)	8 (203) diameter	5 (127)
56U	59 (1499)	56 (1422)	103 (2616)		
74U	77 (1956)	74 (1880)	121 (3075)	10 (254) diameter	6 (152)