



## *X Series Central Granulators*



### *Versatility and Strength For the Toughest Injection Molded Parts*

Cumberland's X Series is one of the most versatile central granulators available. Ideally suited for applications including large injection or blow molded parts, automotive moldings, light purgings, furniture and appliance parts. The X Series comes in 3 widths—27", 39" and 55", with

throughput rates ranging from 1800 to 6000 lbs/hr. The X Series also features low-heat granulation made possible through its unique rotor and cutting chamber design that prevents polymer "melt-down" and virtually eliminates "endplate smearing".

# X Series Central Granulators

## Features

- Unique rotor and disc design reduces frictional heat, helps prevent end plate smearing
- Exclusive Twin Shear slicing action reduces energy consumption, fines and extends knife life
- Split chamber, easy cleanout service access

## Low-Heat Granulation

- Unique rotor and cutting chamber design helps prevent polymer "melt-down"
- Virtually eliminates "endplate smearing"
- End ring (disc) rotates in relationship to the cutting chamber, vastly improving airflow and minimizing frictional heat

## Reduced Energy Consumption

- Made possible by the Twinshear® "scissor cutting" action knife design
- More efficient than chopping motion knife designs
- Uses lower horsepower motor without sacrificing throughput performance

## Easy Accessibility and Clean Out

- Due to split chamber design which raises the upper half of the cutting chamber and lowers the screen cradle and discharge assembly via motorized screw jacks.
- 50% reduction in clean out time
- Simplifies access for knife adjustments and replacement
- Air evacuation piping system does not need to be disconnected

## Low Noise Operation

- Standard double-walled hopper helps avoid the need for sound insulation rooms on plant floor

Specifications	X700	X1000	X1400
Throat Size	600 x 700 mm (24" x 28")	600 x 1000 mm (24" x 40")	600 x 1400 mm (24" x 56")
Cutting Circle	600 mm (23 5/8")		
Throughput (3/8" screen)	820 kg (1800 lbs.)	1200 kg (2500 lbs.)	1600 kg (3500 lbs.)
Infeed	Convey		
Cutting Chamber	(2) Bed Knife Chevron		
Rotor	(3) Knife Chevron		
Rotor Knives	(6) HCHC		
Bed Knives	(4) HCHC		
Screen Diameter	9.4 mm (3/8" dia.)		
Base	Plate Type		
Discharge	Airveyor		
Motor	37 kW (50 HP)	90 kW (100 HP)	90 kW (125 HP)
Drive	V-Belt		
Electrical Components	Safety switches wired into common junction box		
Controls	To suit voltage - 110V at operator station		
Labels	Labels and plates provided for operator safety		
Accessories	Conveyors, blowers, cyclone separators to suit application		
Feed Height	2175 mm (104 3/4")		
Length	2660 mm (104 3/4")		
Width	1473 mm (58")	1778 mm (70")	2184 mm (86")
Height	3429 mm (125")		
Weight	4545 kg (10,000 lbs)	5910 kg (13,000 lbs)	7270 kg (16,000 lbs)

Ruggedly built to international standards, these machines will handle a wide variety of applications including bulky blow molded parts, thermoformed web and cut-sheet products, extruded sheet and film, plus the full gamut of post-consumer plastics for recycling operations.

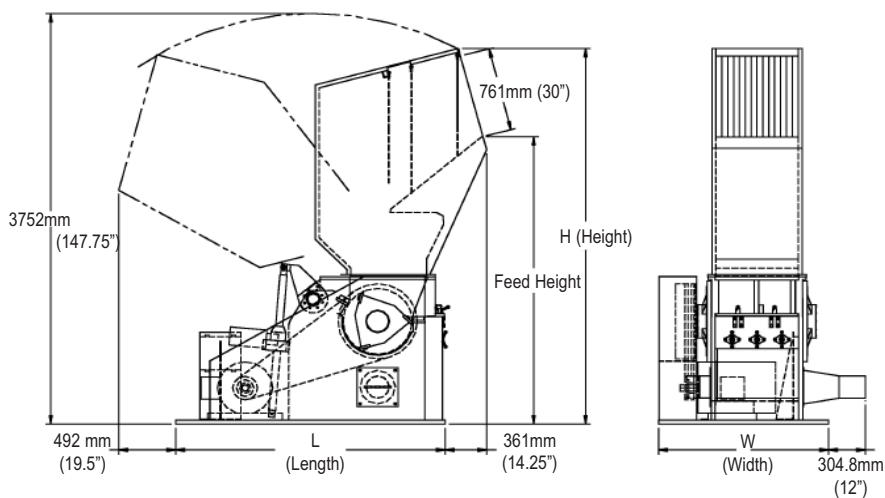

### CORPORATE HEADQUARTERS

2900 S. 160th Street  
New Berlin, WI 53151  
TEL: (262) 641-8600  
FAX: (262) 641-8653  
[www.cumberland-plastics.com](http://www.cumberland-plastics.com)

### REGIONAL SERVICE CENTERS (800) 229-2919

ACS Tech Center  
4100 Market Place  
Flint, MI 48507  
TEL: (810) 720-7300  
FAX: (810) 720-2598

ALL DATA SUBJECT TO CHANGE WITHOUT NOTICE

©2010 Cumberland Engineering

Bulletin CG6-115.3